



12LSX-28

12V 28Ah
Design lifetime: 10 years



Q-Batteries 12LSX-28 is an AGM battery with extended design lifetime of 10 years. It is designed for stand-by applications such as emergency-lighting or UPS-systems.

Application:

burglar-systems, UPS-systems,
emergency-lighting-systems



Specification:

Voltage Per Unit	12 V		
Capacity	28 Ah (10 h)		
Cells Per Unit	6		
Weight	9.3kg +/- 3%		
Max. Discharge Current	310 A (5 sec.)		
Operating Temperature Range	Discharge:	Charge:	Storage:
Normal	- 20°C – 60°C	-10°C – 60°C	- 20°C – 60°C
Self Discharge	Valve Regulated Lead Acid (VRLA) batteries can be stored for more than 6 months at 25°C. Self-discharge ratio less than 3% per month at 25°C. Please charge batteries before using.		
Terminal	F13		
Technology	AGM, Absorbent glass mat technology		
Container Material	A.B.S. (UL-94 V0)		

Dimensions:

165 mm Length x 125 mm Width x 175 mm Height

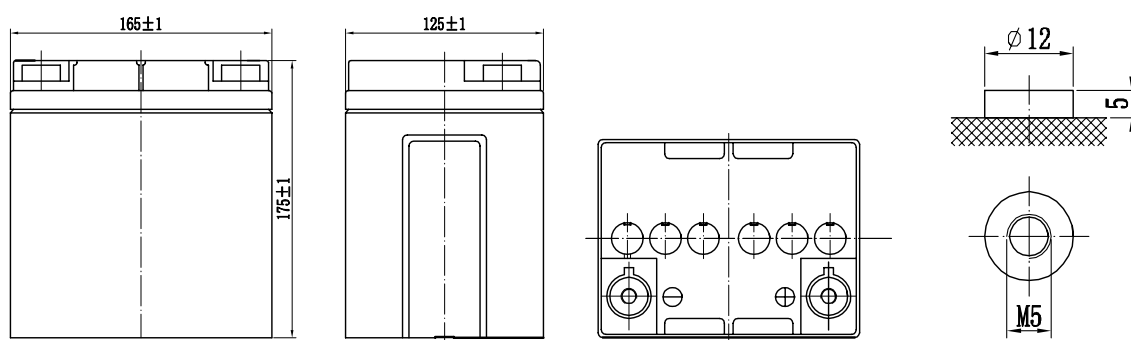

Constant current discharge characteristics: A (25°C)

F.V / Time	5 MIN	10 MIN	15 MIN	30 MIN	1 HR	2 HR	3 HR	4 HR	5 HR	10 HR	20 HR
1.60V	112	73.0	55.0	32.0	19.6	8.02	5.20	2.82	1.47		
1.65V	106	69.5	52.6	30.7	18.9	7.77	5.08	2.82	1.46		
1.70V	100	65.9	50.1	29.4	18.1	7.50	4.95	2.81	1.45		
1.75V	93.9	62.2	47.5	28.0	17.3	7.20	4.80	2.80	1.44		
1.80V	87.6	58.5	44.8	26.5	16.5	6.88	4.63	2.80	1.42		

Constant power discharge characteristics: Watt (25°C)/cell

F.V / Time	5 MIN	10 MIN	15 MIN	30 MIN	1 HR	2 HR	3 HR	4 HR	5 HR	10 HR	20 HR
1.60V	208	135	105	61.7	46.7	36.7	24.0	16.0	10.4		
1.65V	195	127	99.3	58.6	44.5	35.1	23.3	15.6	10.2		
1.70V	183	119	93.6	55.4	42.3	33.5	22.5	15.2	10.0		
1.75V	170	111	87.8	52.2	40.0	31.8	21.6	14.4	9.9		
1.80V	157	104	82.0	49.0	37.7	30.1	20.7	13.8	9.8		

Storage characteristic:

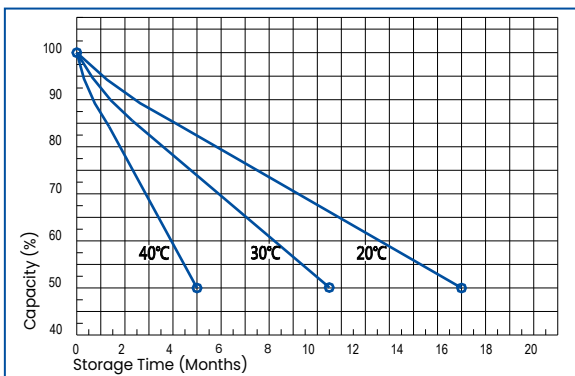

Capacity Factors with different Temperature:

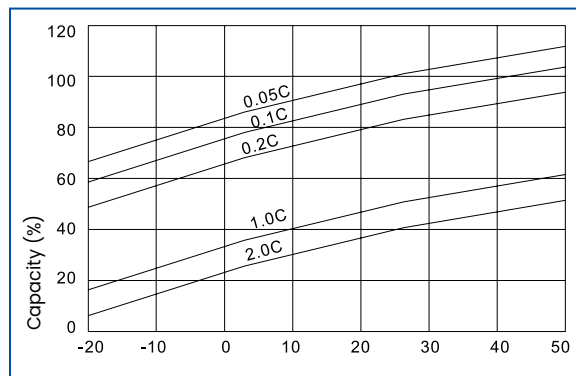

Charging Method:

Recharge after use, at least every 6th month:

Cyclic charging voltage
14,4 to 15,0 V (25°C)

Float charging voltage (25°C)
13,5 to 13,8 V (25°C)

Maximum charging current
3A

Do not short circuit the battery.